

HP44

SL 4.0
Quad-zones controller

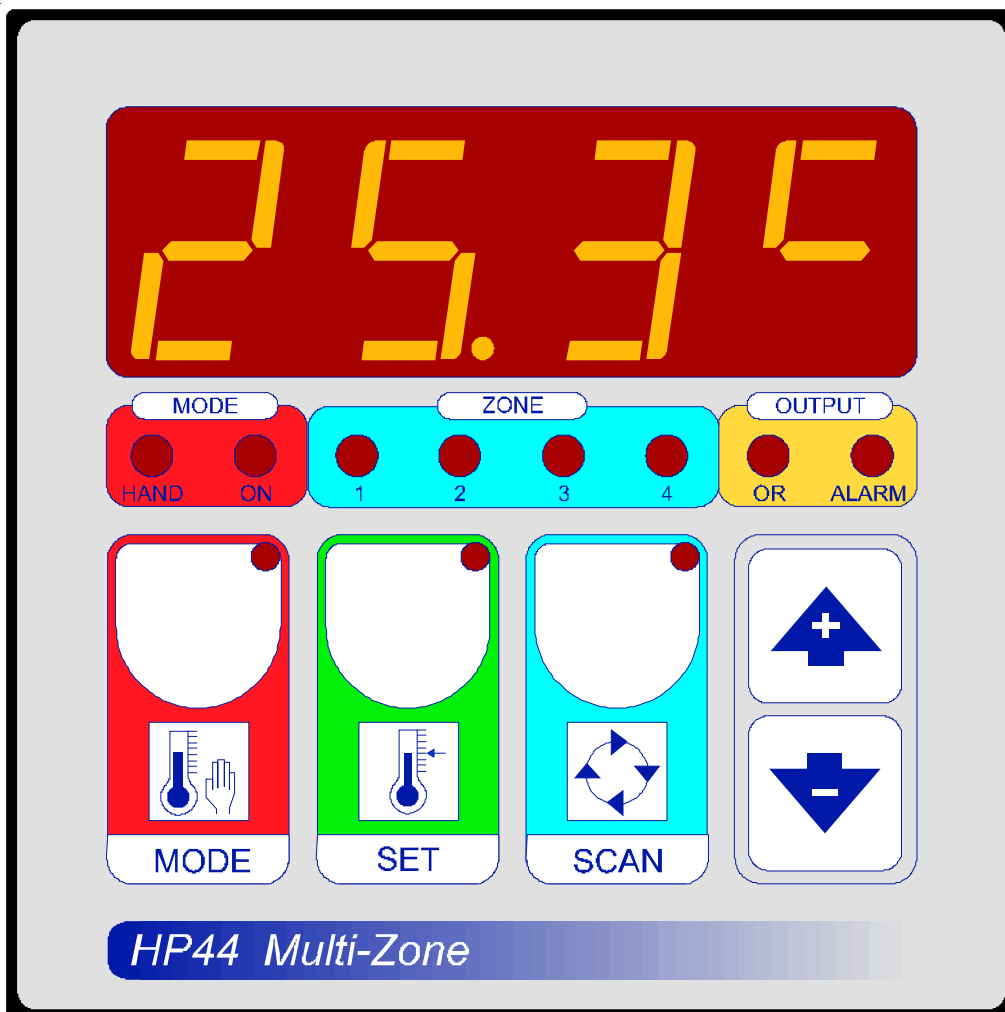

MAIN SETTINGS (Run mode)

These settings are only concerning the user and are made during the run mode as follows.

AUTO/HAND SELECTION (only with *tyPE=1, =2* see *Cost*)

Press **SCAN** several times to move to Zone required (Zone light comes on).



Press **MODE** (key lamp flashes):

This message referring to the set condition, will be displayed (**Auto**= Automatic, **-on-**= always On, **-oF-** = always Off).

Press **+** or **-** to modify, press **MODE** to confirm.

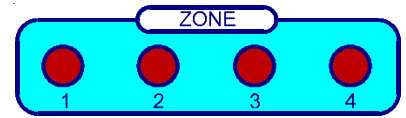

TEMPERATURE SETTING

Press **SCAN** several times to move to the zone to program (Zone light comes on).

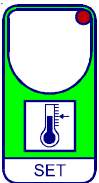

Press **SET** (key lamp flashes):

This message will be displayed instead of the °Set Zone value select.

Press **+** or **-** to modify, press **SET** to confirm.

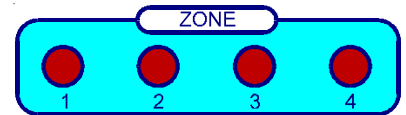

ZONE 1 EXAMPLE



ZONE 1 EXAMPLE



ZONE 1 EXAMPLE

At this point this message will be displayed instead of the °Set Minimum Temperature value.

Press **+** or **-** to modify, press **SET** to confirm.

At this point this message will be displayed instead of the °Set Maximum Temperature value.

Press **+** or **-** to modify, press **SET** to confirm.

INPUT DISPLAY.

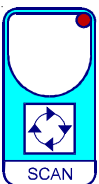

Press **SCAN** several times to move to the Zone to display (Zone light comes on).

The display will show the value measured by the temperature sensor of the selected area, on **MODE** light if the Zone is in **HAND**, and if it's **ON**.

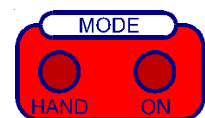
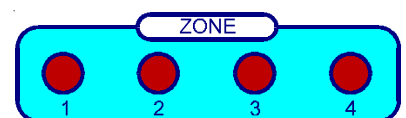

EXAMPLE WITH °C TEMPERATURE

COS_t PROGRAMMING (System constants)



These settings refer to the operation mode of the system and must be made on initial startup. Press - / + at the same time for at least one second: the message **C.O.S.t.** will be displayed.



Press then repeatedly **SCAN** until the message regarding the chosen variable is displayed (see table below) : value of variable and message will be displayed.

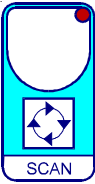

Press + or - to set a new value and then press **SCAN** to confirm.

The next system constant will then appear.

You can press **SCAN** for at least 2 seconds to exit and return to the Run Mode.

| Mess. | Valore | Significato | Note |
|--------------|-------------|--|-----------|
| diF.1 | 0.2° | ° Zone 1 differential | *1 |
| diF.2 | 0.2° | ° Zone 2 differential | *1 |
| diF.3 | 0.2° | ° Zone 3 differential | *1 |
| diF.4 | 0.2° | ° Zone 4 differential | *1 |
| rEL.1 | 0.0° | ° Setting shift referring to the Set.1 | *1 |
| rEL.2 | 0.0° | ° Setting shift referring to the Set.2 | *1 |
| rEL.3 | 0.0° | ° Setting shift referring to the Set.3 | *1 |
| rEL.4 | 0.0° | ° Setting shift referring to the Set.4 | *1 |
| inPu | =4 | Number of Zones (probes) connected | |
| tYPE | =1 | Actioning type | *2 |
| i.1 | =1 | Input 1 selection | *3 |
| i.2 | =1 | Input 2 selection | *3 |
| i.3 | =1 | Input 3 selection | *3 |
| i.4 | =1 | Input 4 selection | *3 |
| Ad.t1 | 0.0 | °Input 1 correction (+ or -) | *4 |
| Ad.t2 | 0.0 | °Input 2 correction (+ or -) | *4 |
| Ad.t3 | 0.0 | °Input 3 correction (+ or -) | *4 |
| Ad.t4 | 0.0 | °Input 4 correction (+ or -) | *4 |

*1) For more details see *Operative Diagrams*.

*2) **HP44** can be configured in these different actioning type:

=1 : 4 HEAT actioning (4 Sets / 4 Inputs)

=2 : 4 COOL actioning (4 Sets / 4 Inputs)

=3 : 4 HEAT actioning (1 Set / 1 Inputs)

=4 : 3 HEAT actioning + 1 COOL actioning (1 Set / 1 Input)

=5 : 2 HEAT actioning + 2 COOL actioning (1 Set / 1 Input)

=6 : 1 HEAT actioning + 3 COOL actioning (1 Set / 1 Input)

=7 : 4 COOL actioning (1 Set / 1 Input)

For more details see *Operative diagrams*.

***3)** These types of input can be set for each Zone:

| | Input connect | Range | Risolution | Dip Switch |
|----|---------------|--------------------|------------|-----------------|
| =1 | SX Pola (°C) | -50.0°C...+115.0°C | 0.1°C | 0 |
| =2 | SX Pola (°C) | -58.0°F...+239.0°F | 0.1°F | 0 |
| =3 | PT100 (°C) | -50°C...+600°C | 1°C | 1 |
| =4 | PT100 (°F) | -58°F...+1112°F | 2°F | 1 |
| =5 | PT1000 (°C) | -200°C...+300°C | 1°C | 1 |
| =6 | PT1000 (°F) | -328°F...+572°F | 2°F | 1 |
| =7 | 4-20mA | 0.0%...+100.0% | 0,1 | 0 ^{*A} |

Note *A:

tEnp= 7 : Input 4-20mA connection

⊖ terminals 11-13-15-17

⊕ terminals 12-14-16-18

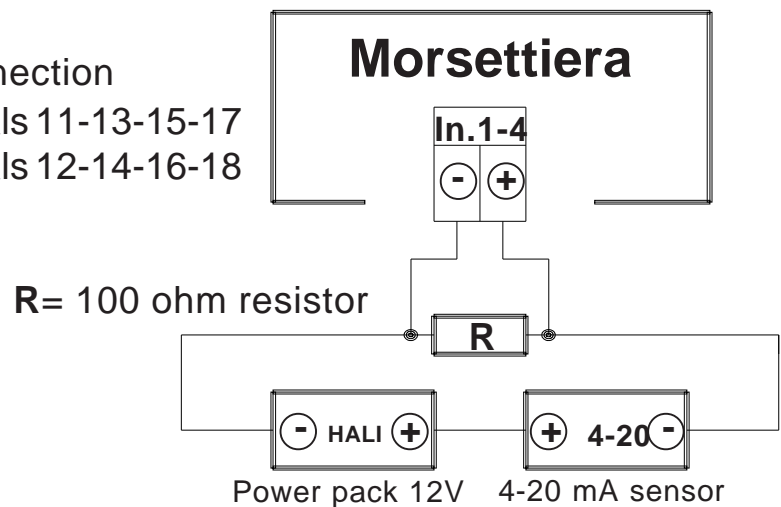

Caution: Selected the pertaining slide/channel (Dip-Switch see *Installation*).

***4)** You can correct the readings on the various sensors (+ or -).

PRESET PROGRAMS (Bootstrap)

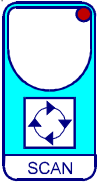

This processor is already programmed with the following (variable) settings. To return to these settings at any time you may:
Power off the processor, press **ALARM** key and keep it pressed giving power on: **boot** message will be displayed (release now **ALARM** key).

SEt. 1/4= 25.0° **AL-1/4**= 10.0° **AL-1/4**= 40.0°

The COSt values are shown in **COSt Programming**.

MANUAL MODE

In some start-up conditions may be useful to work in "manual" mode:



Power off the processor, press **+** key and keep it pressed giving power on: **HAnd** message will be displayed (release now **+** key).

Push **+** until is displayed number required to be handed (see table *State indication lamps*) and push **SCAN** for activating relay.

Pushing again **+** for increase relay number previous relay is deactivated.

You can press **SCAN** key for a least two seconds to escape and return to the *Run Mode*.

STATE INDICATION LAMPS

The light situated at the bottom of the display shows the state of the controller:

| Lamp. | State | N°Relay | Contacts |
|--------------|--------------------------------|---------|------------------|
| HAND | Zone selected on HAND (Off/On) | - | - |
| ON | Zone selected On (1-2-3-4) | 1-2-3-4 | 3-4/5-6/7-8/9-10 |
| 1 | Zone 1 selected | - | |
| 2 | Zone 2 selected | - | |
| 3 | Zone 3 selected | - | |
| 4 | Zone 4 selected | - | |
| OR | Logic or relay On | 6 * | 3-4-5 * |
| ALARM | Min-Max alarm On (n.c.) | 7 * | 6-7-8 * |

Lamp **1-2-3-4** flashing if Zone not viewing is in Alarm condition.

* Available only with **HPAL** slot option (see **HPAL** handbook).

OPERATIVE DIAGRAMS

typE=1 (see COSt): 4 HEAT actioning (4 Sets / 4 Inputs)

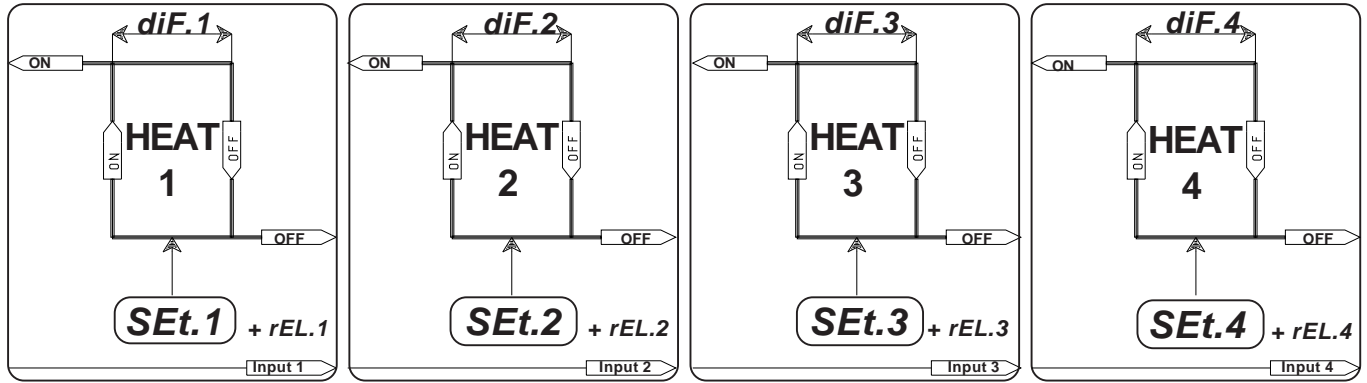

typE=2 (see COSt): 4 COOL actioning (4 Sets / 4 Inputs)

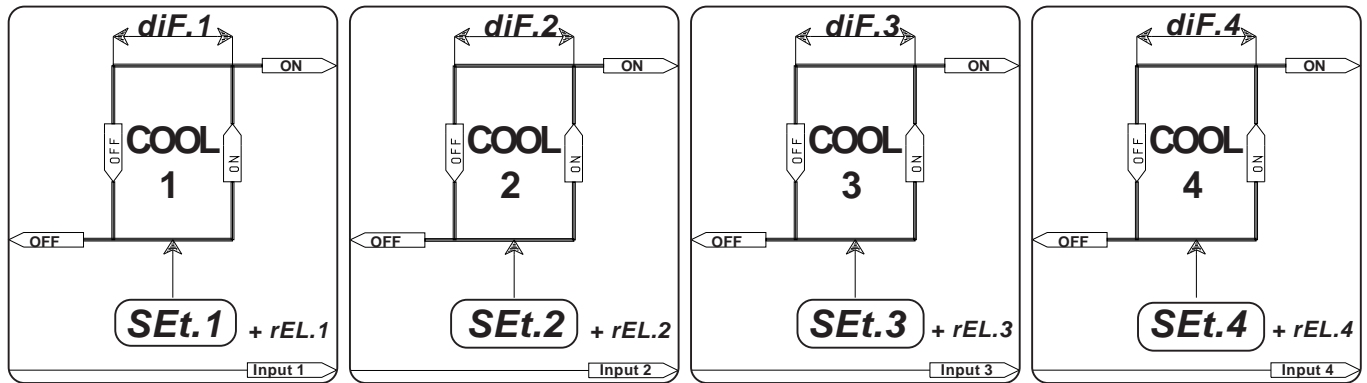

typE=3 (see COSt): 4 HEAT actioning (1 Set / 1 Input)

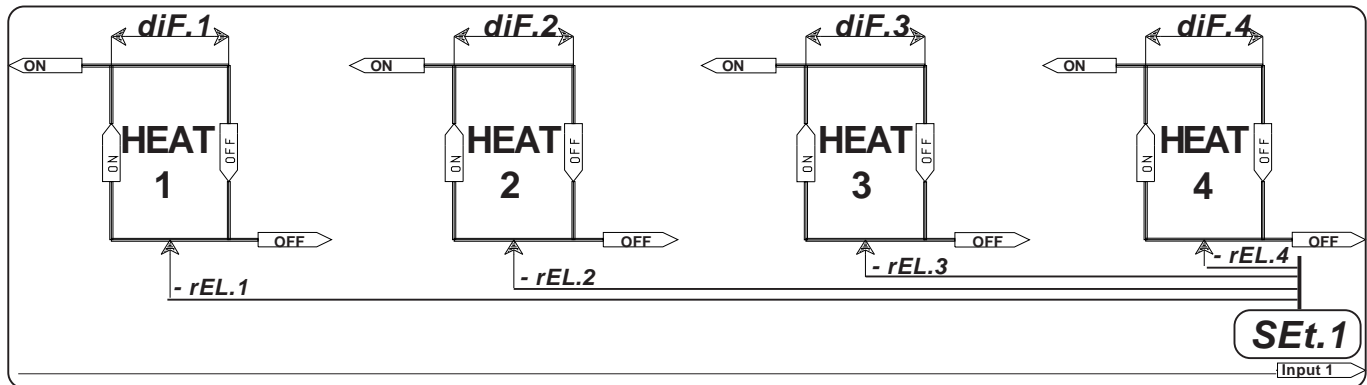

typE=4 (see COSt): 3 HEAT actioning + 1 COOL actioning (1 Set / 1 Input)

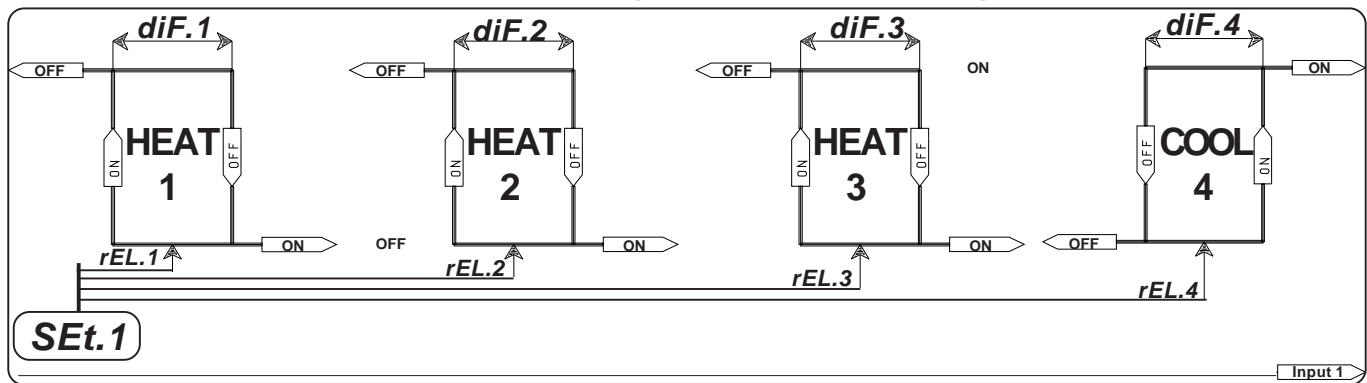

typE=5 (see COSt): 2 HEAT actioning + 2 COOL actioning (1 Set/1 Input)

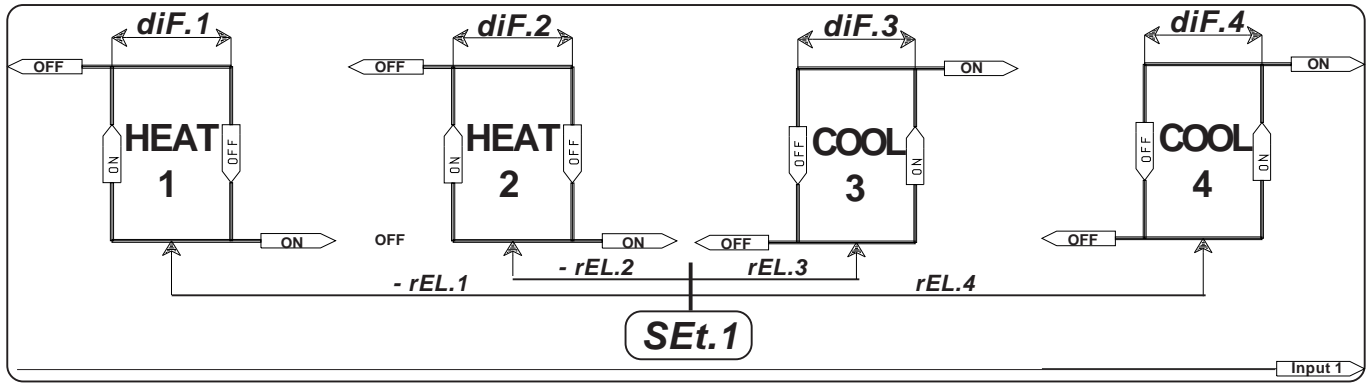

typE=6 (see COSt): 1 HEAT actioning + 3 COOL actioning (1 Set/1 Input)

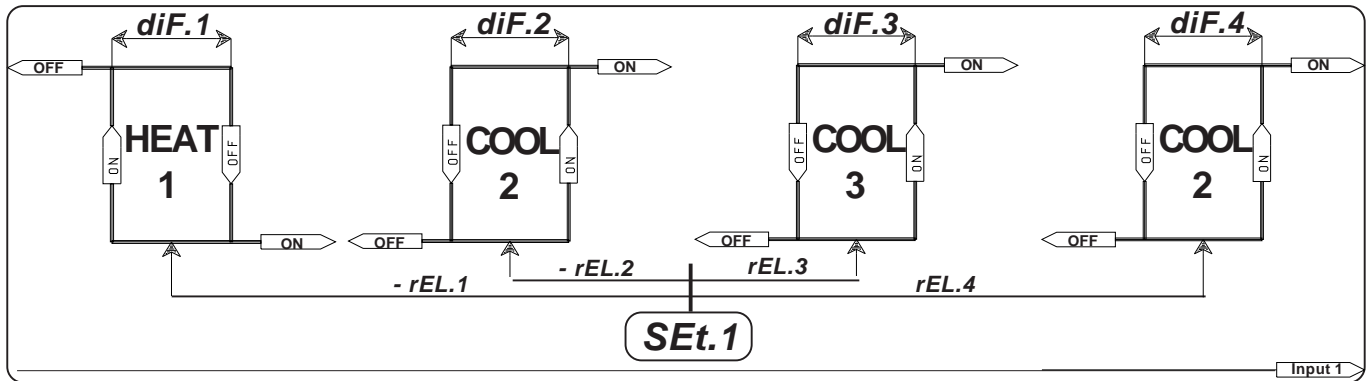

typE=7 (see COSt) : 4 COOL actioning (1 Set / 1 Input)

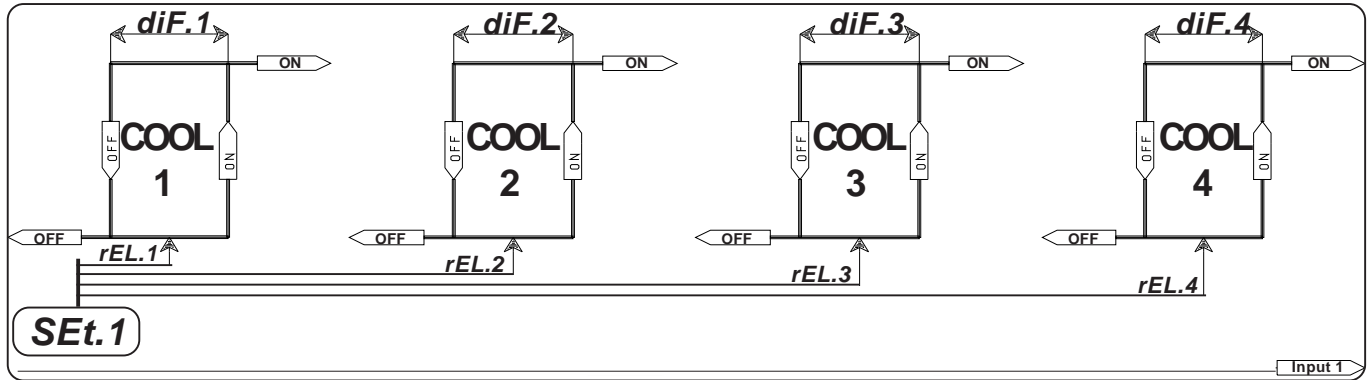

INSTALLATION

For correct installation, follow the instructions below very carefully.

You are recommended to install the controller properly so that it complies with current regulations, and also to use a max 4Amp.F fuse to prevent the relay output contacts from getting damaged and ensure they stay in perfect running order (terminals 3-4... 9-10 of the HP module connector).

How to connect the sensors

Connect the provided sensors as shown in the diagram (see following page).

For remote connections use a standard 0.5-square millimetre two-pole wire for each sensor, taking great care over the connections, by insulating and sealing the joins carefully.

How to connect the line

Connect line on terminals **L-N**; protect supply with adequate fuse.

How to connect the contacts

Connect terminals **3-4...9-10** on the terminal block (contacts up to 4AMP.AC1) to the loads as shown in the diagram (see overleaf).

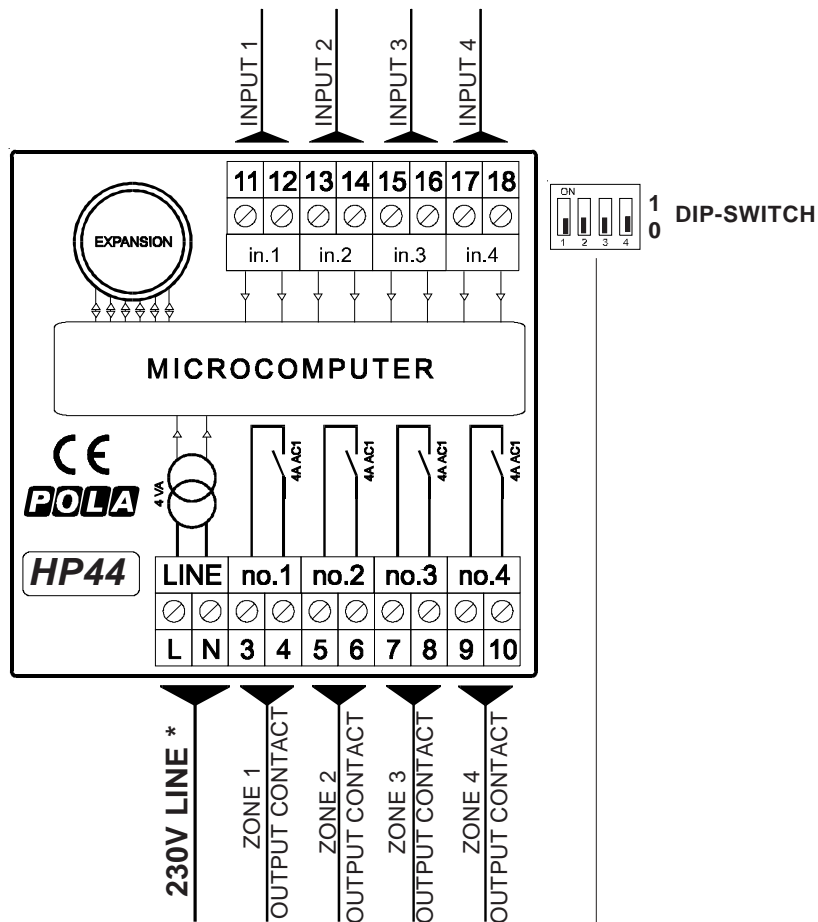

* Other power voltage if you required.

Caution: Selected the 4 slide/channel Dip-Switch (see Cost, note *3).

As it company policy to continually improve the products the Manufacturers reserve the right to make any modifications thereto without prior notice. They cannot be held liable for any damage due to malfunction.

POLA®

CE



02.01.13